

ANALYSIS OF CONTINUOUS TRUSS-FRAMES,
BY SLOPE DEFLECTION AND MOMENT
DISTRIBUTION

By

EZRA DAVID SHOUA

Bachelor of Science (Honors)

University of Khartoum

Khartoum (Sudan)

1960

Submitted to the Faculty of the Graduate School of
the Oklahoma State University
in partial fulfillment of the requirements
for the degree of
MASTER OF SCIENCE
January, 1962

NOV 13 1962

ANALYSIS OF CONTINUOUS TRUSS-FRAMES
BY SLOPE DEFLECTION AND MOMENT
DISTRIBUTION

Thesis Approved:

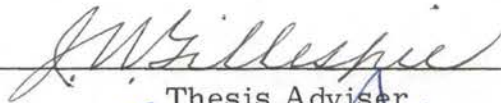

Thesis Adviser

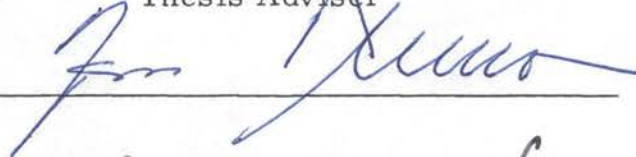



Dean of the Graduate School

505249

PREFACE

The investigation and application presented in this thesis is the extension of material presented in the lectures for Civen 5A4 - Theory of Structures III by Professor James W. Gillespie in the summer, 1961⁽¹⁾. A selected bibliography, which includes only those references which had a direct influence on this thesis, is included.

The writer, in completing the final phase of his work for his Master's Degree wishes to express gratitude to the following persons:

To Professor Jan J. Tuma, Head, Civil Engineering Department, not only for providing him with graduate assistantship, but also for his invaluable friendship, guidance and encouragement during his advanced study.

To Professor James W. Gillespie, his major advisor, for his great help and guidance throughout the preparation of this thesis.

To Professors E. J. Waller, J. V. Parcher, R. L. Flanders, D. M. MacAlpine and Messrs. J. T. Oden, R. K. Munshi, M. E. Kamel, G. Tveito, C. L. Proctor and R. Matallucci for their helpful interest and encouragement during his academic work.

To Mr. and Mrs. Tom Birbilis, Tulsa, who recommended him to Professor Tuma, and for their kindness and help during his stay in Oklahoma.

To his parents for their patience and encouragement during his graduate study.

To Mrs. Mary Jane Walters for her excellent job in typing and checking the entire manuscript.

Stillwater, Oklahoma
January 25, 1962

E. D. Shoua

TABLE OF CONTENTS

Chapter	Page
I. INTRODUCTION	1
1. General	1
2. Assumptions	2
3. Sign Convention	2
II. DEFORMATION EQUATIONS	3
1. General	3
2. Derivation	5
3. Elastic Center	12
4. Physical Interpretation and Definitions	15
III. MODIFIED DEFORMATION EQUATIONS FOR PRISMATIC COLUMNS	25
1. General	25
2. Derivation	25
IV. MOMENT DISTRIBUTION	30
1. General	30
2. Modification	31
3. Procedure	33
V. APPLICATION	35
1. General	35
2. Procedure	35
3. Numerical Example	36
VI. SUMMARY AND CONCLUSION	46
1. Summary	46
2. Conclusions	47
3. Extension	47
A SELECTED BIBLIOGRAPHY	48

LIST OF TABLES

Table		Page
5-1.	Elastic Constants and Load Functions	38
5-2.	Comparison of Results	45

LIST OF FIGURES

Figure	Page
2-1. Continuous Truss Frame	3
2-2. Typical Truss Element	4
2-3. Basic Structure	5
2-4. Transfer of Horizontal Force	13
2-5. Transfer of Vertical Force	14
2-6. Deformations Due to $X_1 = 1$	15
2-7. Deformations Due to $X_2 = 1$	16
2-8. Deformations Due to $X_3 = 1$	17
2-9. Deformations Due to Loads	18
2-10. Angular Stiffness Constants	19
2-11. Horizontal Linear Stiffness Constants	21
2-12. Vertical Linear Stiffness Constants	22
2-13. Fixed End Reactions	23
3-1. Typical Intermediate Column	26
5-1. Two-Span Truss Frame	36
5-2. Basic Structure	37
5-3. Free Body Diagram	41

NOMENCLATURE

a_{ij}	Elastic Constant.
b_{ij}	Matrix Element.
d_n	Length of Truss Member.
d_j	Effective Length of Column.
d_{avg}	Average Length of Column.
h_j	End Depth of Truss.
A_n	Area of Truss Member.
B_{ij}	Thrust Carry-Over Factor.
BH_{ij}	Thrust Due to Loads.
BM_{ij}	Moment Due to Loads.
BN_n	Normal Force in Truss Member Due to Loads.
C_{ij}	Angular Carry-Over Factor.
D_{ji}	Distribution Factor.
E_{ij}	Angular-Horizontal Linear Carry-Over Stiffness Factor.
E	Modulus of Elasticity.
FH_{ij}	Fixed End Thrust.
FM_{ij}	Fixed End Moment.
H_{ij}	Thrust Force.

I	Moment of Inertia.
K_{ij}	Angular Stiffness Factor.
L_j	Span Length.
M_{ij}	End Moment.
N_n	Normal Force in Truss Member.
RH_{ij}	Rotational Thrust.
RM_{ij}	Rotational Moment.
S_{ij}	Fixed End Angular Stiffness Factor.
T_{ij}	Fixed End Thrust Stiffness Factor.
U	Strain Energy.
V	Shearing Force.
X_1	Redundant Moment at Elastic Center.
X_2	Redundant Shear at Elastic Center.
X_3	Redundant Thrust at Elastic Center.
α_n	Normal Force in Truss Member Due to $X_1 = 1$.
β_n	Normal Force in Truss Member Due to $X_2 = 1$.
γ_n	Normal Force in Truss Member Due to $X_3 = 1$.
θ	Angular Rotation.
λ_n	Axial Flexibility.
λ'_n	Relative Axial Flexibility.
ρ_{ij}	Thrust Induction Factor.
Δ	Linear Displacement
\sum_n	Summation Over the Entire Structure.

CHAPTER I

INTRODUCTION

1-1. General

The "exact" analysis of truss frames has been based largely on "work" methods. The application of these work methods is quite awkward for many cases, especially for truss frames of several spans. An "approximate" analysis is readily obtained by application of the slope deflection or moment distribution method utilizing certain assumptions. The usual assumption consists of assuming an average column length. Also, for straight trusses, it is common to assume that the horizontal translations at the tops of the assumed average columns are equal. While, in many cases, these simplifications yield sufficiently accurate results, they cannot be relied upon in every case. This is especially true if the trusses are of variable depth or if the cross-sectional areas of the truss members differ sufficiently.

It is obviously desirable therefore, to modify the "approximate" slope deflection procedure to obtain an "exact" approach using the method of slope deflection or moment distribution. The derivation of the "exact" slope deflection procedure is shown in this thesis. The application is illustrated by a numerical example, and the results are compared with the "approximate" solution.

General slope deflection equations for a truss of general shape are presented in this thesis. Similar equations were derived earlier by

Smith⁽²⁾. The real contribution of this thesis is the modification of the slope deflection equations for prismatic columns to establish compatibility of deformations at the truss-column connection. These modified equations combined with the deformation equations for the truss yield an "exact" analysis using the regular slope deflection or moment distribution method.

1-2. Assumptions

The usual assumptions of truss analysis are assumed valid in this thesis. These assumptions are:

- (1) Connections are frictionless cylindrical hinges
- (2) Truss members can resist only axial forces
- (3) Truss and loads form a coplanar system
- (4) Loads are applied at joints as concentrated forces
- (5) Deformations are small and elastic.

1-3. Sign convention

The sign convention of the slope deflection method is adopted for end reactive elements and deformations. The positive reactive moments and angular rotations are clockwise. The positive reactive linear forces and displacements are to the right and upward. Axial forces are considered as positive if they are subjecting the member to tension.

CHAPTER II

DEFORMATION EQUATIONS

2-1. General

Slope deflection equations for continuous truss frames of any general shape are desired. These equations are derived using the method of least work.

A typical continuous truss frame of general shape loaded by a general system of forces is considered (Fig. 2-1).

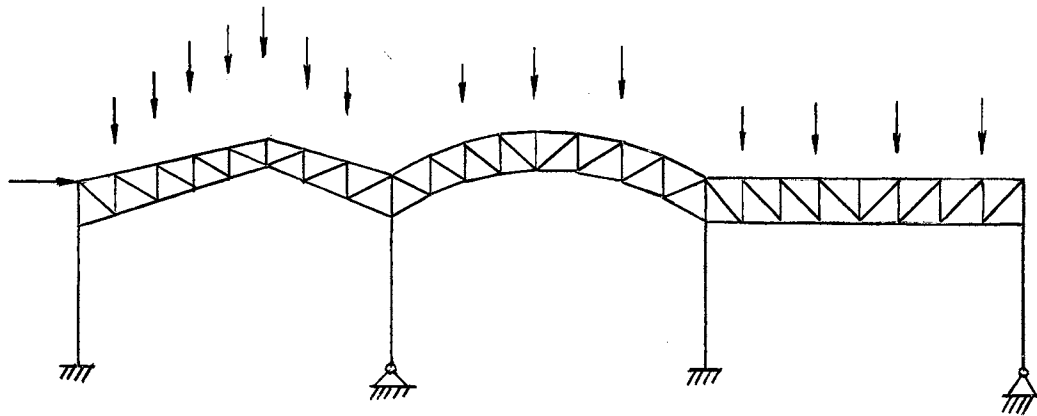

Fig. 2-1

Continuous Truss Frame

Under the action of this general system of forces, the structure is subjected to three independent deformations at each joint; thus, at a typical joint (j), these deformations are θ_j , Δ_{jx} and Δ_{jy} .

A typical truss element \bar{ij} of the structure is shown with the end reactions denoted as M_{ij} , V_{ij} , H_{ij} at end (i) and M_{ji} , V_{ji} , H_{ji} at end (j) (Fig. 2-2). The defining dimensions of the truss element are indicated. The end deformations are shown and denoted θ_i , Δ_{ix} , Δ_{iy} , and θ_j , Δ_{jx} , Δ_{jy} at ends (i) and (j) respectively. Linear deformations are referred to the bottom chord of the truss element, and angular deformations are defined as the rotation of the lines connecting the bottom and top joints, (i) and (i') , (j) and (j') respectively.

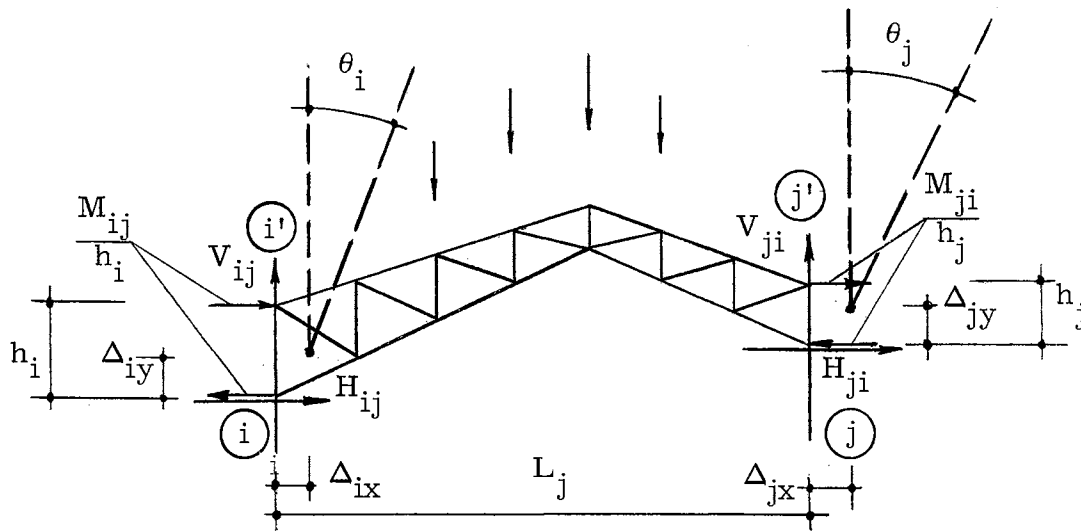

Fig. 2-2

Typical Truss Element

Because of the simplifications associated with the application of redundants at the "elastic center", the elastic center approach is used in deriving deformation equations for the end moments and thrusts. These redundants are evaluated at the elastic center and then transferred to the ends, thus formulating the desired slope deflection equations. The end shears can be determined from the end moments and thrusts by statics, thus eliminating the necessity for having deformation equations

for end shears.

2-2. Derivation

A typical truss element loaded by a general system of forces is split between two panels and an infinitely rigid arm is extended to the elastic center (Fig. 2-3). This structure is referred to as the "basic structure".

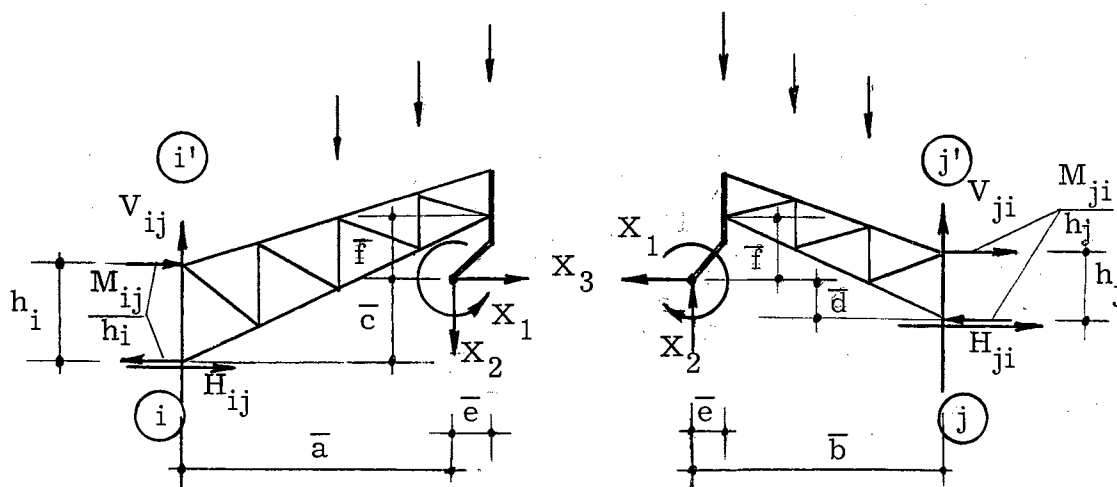

Fig. 2-3

Basic Structure

The redundants at the elastic center are denoted X_1 , X_2 , X_3 and the location of the elastic center is specified by dimensions \bar{a} , \bar{b} , \bar{c} and \bar{d} .

The end reactions are:

End Moments:

$$\begin{aligned} M_{ij} &= BM_{ij} + X_1 - X_2 \bar{a} - X_3 \bar{c} \\ M_{ji} &= BM_{ji} - X_1 - X_2 \bar{b} - X_3 \bar{d} \end{aligned} \quad (2-1)$$

End Thrusts:

$$\begin{aligned} H_{ij} &= BH_{ij} - X_3 \\ H_{ji} &= BH_{ji} + X_3 \end{aligned} \quad (2-2)$$

End Shears:

$$\begin{aligned} V_{ij} &= BV_{ij} + X_2 \\ V_{ji} &= BV_{ji} - X_2 \end{aligned} \quad (2-3)$$

where

BM_{ij} = End moment at (i) on the basic structure \bar{ij} due to loads.

BM_{ji} = End moment at (j) on the basic structure \bar{ij} due to loads.

BH_{ij} = End thrust at (i) on the basic structure \bar{ij} due to loads.

BH_{ji} = End thrust at (j) on the basic structure \bar{ij} due to loads.

BV_{ij} = End shear at (i) on the basic structure \bar{ij} due to loads.

BV_{ji} = End shear at (j) on the basic structure \bar{ij} due to loads.

The normal force in any member n is

$$N_n = BN_n + X_1\alpha_n + X_2\beta_n + X_3\gamma_n$$

where

BN_n = Normal force in member n of the basic structure \bar{ij} due to loads.

α_n = Normal force in member n of the basic structure \bar{ij} due to $X_1 = 1$.

β_n = Normal force in member n of the basic structure \bar{ij} due to $X_2 = 1$.

γ_n = Normal force in member n of the basic structure
 \bar{ij} due to $X_3 = 1$.

The total elastic energy stored in the structure is

$$U_s = \sum_n \frac{N_n^2 \lambda_n}{2}$$

where

$$\lambda_n = \frac{d_n}{A_n E} = \text{Axial extensibility of member n.}$$

d_n = Length of member n.

A_n = Area of member n.

E = Modulus of Elasticity.

\sum_n = Summation over the entire structure \bar{ij} .

The end reactions \textcircled{i} and \textcircled{j} are subjected to the deformations $\theta_i, \Delta_{ix}, \Delta_{iy}$ and $\theta_j, \Delta_{jx}, \Delta_{jy}$, respectively. The total work done by the reactions as a result of these deformation is

$$U_r = M_{ij} \theta_i + H_{ij} \Delta_{ix} + V_{ij} \Delta_{iy} + M_{ji} \theta_j + H_{ji} \Delta_{jx} + V_{ji} \Delta_{jy}.$$

The total energy stored in the system is

$$U = U_s - U_r,$$

and from the theorem of least work

$$\frac{\partial U}{\partial X_1} = 0 \qquad \frac{\partial U}{\partial X_2} = 0 \qquad \frac{\partial U}{\partial X_3} = 0$$

or

$$\frac{\partial U_s}{\partial X_1} = \frac{\partial U_r}{\partial X_1} \qquad \frac{\partial U_s}{\partial X_2} = \frac{\partial U_r}{\partial X_2} \qquad \frac{\partial U_s}{\partial X_3} = \frac{\partial U_r}{\partial X_3}.$$

Performing the indicated operations, and writing the result in matrix form

$$\begin{bmatrix} a_{11} & a_{12} & a_{13} & a_{10} \\ a_{21} & a_{22} & a_{23} & a_{20} \\ a_{31} & a_{32} & a_{33} & a_{30} \\ & & & 1 \end{bmatrix} \begin{bmatrix} X_1 \\ X_2 \\ X_3 \\ 1 \end{bmatrix} = \begin{bmatrix} +1 & -1 & - & - \\ -\bar{a} & -\bar{b} & - & -1 \\ -\bar{c} & +\bar{d} & +1 & - \end{bmatrix} \begin{bmatrix} \theta_i \\ \theta_j \\ \Delta_{jix} \\ \Delta_{jiy} \end{bmatrix} \quad (2-4)$$

where the terms in the coefficient matrix

$$\begin{bmatrix} a_{11} & a_{12} & a_{13} & a_{10} \\ a_{21} & a_{22} & a_{23} & a_{20} \\ a_{31} & a_{32} & a_{33} & a_{30} \end{bmatrix}$$

are defined and illustrated in Section 2-4, and

$$\begin{aligned} \overrightarrow{\Delta}_{jix} &= \overrightarrow{\Delta}_{jx} - \overrightarrow{\Delta}_{ix} \\ \uparrow \Delta_{jiy} &= \uparrow \Delta_{jy} - \uparrow \Delta_{iy} \end{aligned}$$

Transposing the submatrix of load functions

$$\begin{bmatrix} a_{10} \\ a_{20} \\ a_{30} \end{bmatrix}$$

to the right, the final matrix equation becomes

$$\begin{bmatrix} a_{11} & \cancel{a_{12}} & \cancel{a_{13}} \\ \cancel{a_{21}} & a_{22} & a_{23} \\ a_{31} & a_{32} & a_{33} \end{bmatrix} \begin{bmatrix} X_1 \\ X_2 \\ X_3 \end{bmatrix} = \begin{bmatrix} +1 & -1 & - & - & a_{10} \\ -\bar{a} & -\bar{b} & - & -1 & a_{20} \\ -\bar{c} & +\bar{d} & +1 & - & a_{30} \end{bmatrix} \begin{bmatrix} \theta_i \\ \theta_j \\ \Delta_{jix} \\ \Delta_{jiy} \\ -1 \end{bmatrix} \quad (2-5)$$

and since by the definition of the elastic center and Maxwell's reciprocal principle

$$a_{12} = a_{21} = 0$$

$$a_{13} = a_{31} = 0,$$

these terms are eliminated.

Also for the special case when the structure is symmetrical,

$$a_{23} = a_{32} = 0.$$

Premultiplying Equation (2-5) by the inverse of the coefficient matrix, the redundant matrix is

$$\begin{bmatrix} X_1 \\ X_2 \\ X_3 \end{bmatrix} = \begin{bmatrix} a_{11} & - & - \\ & a_{22} & a_{23} \\ - & a_{32} & a_{33} \end{bmatrix}^{-1} \begin{bmatrix} +1 & -1 & - & - & a_{10} \\ -\bar{a} & -\bar{b} & - & -1 & a_{20} \\ -\bar{c} & +\bar{d} & +1 & - & a_{30} \end{bmatrix} \begin{bmatrix} \theta_i \\ \theta_j \\ \Delta_{jix} \\ \Delta_{jiy} \\ -1 \end{bmatrix} \quad (2-6)$$

or

$$\begin{bmatrix} X_1 \\ X_2 \\ X_3 \end{bmatrix} = \begin{bmatrix} b_{11} & b_{12} & b_{13} & b_{14} & b_{15} \\ b_{21} & b_{22} & b_{23} & b_{24} & b_{25} \\ b_{31} & b_{32} & b_{33} & b_{34} & b_{35} \end{bmatrix} \begin{bmatrix} \theta_i \\ \theta_j \\ \Delta_{jix} \\ \Delta_{jiy} \\ +1 \end{bmatrix} \quad (2-6a)$$

where

$$b_{11} = + \frac{1}{a_{11}}$$

$$b_{12} = - \frac{1}{a_{11}}$$

$$b_{13} = b_{14} = 0$$

$$b_{15} = - \frac{a_{10}}{a_{11}}$$

$$b_{21} = - \bar{a} \frac{a_{33}}{n} + \bar{c} \frac{a_{23}}{n}$$

$$b_{22} = - \bar{b} \frac{a_{33}}{n} - \bar{d} \frac{a_{23}}{n}$$

$$b_{23} = - \frac{a_{23}}{n}$$

$$b_{24} = - \frac{a_{33}}{n}$$

$$b_{25} = - \frac{a_{23}}{n} a_{20} + \frac{a_{23}}{n} a_{30}$$

$$b_{31} = - \bar{c} \frac{a_{22}}{n} + \bar{a} \frac{a_{32}}{n}$$

$$b_{32} = +\bar{d} \frac{a_{22}}{n} + \bar{b} \frac{a_{32}}{n}$$

$$b_{33} = + \frac{a_{22}}{n}$$

$$b_{34} = + \frac{a_{32}}{n}$$

$$b_{35} = - \frac{a_{22}}{n} a_{30} + \frac{a_{32}}{n} a_{20} ,$$

and

$$n = a_{22} a_{33} - a_{23} a_{32} .$$

Transferring the redundants at the elastic center to the ends

(i) and (j) by Equations (2-1) and (2-2)

$$\begin{bmatrix} M_{ij} \\ M_{ji} \\ H_{ij} \\ H_{ji} \end{bmatrix} = \begin{bmatrix} 1 & -\bar{a} & -\bar{c} & BM_{ij} \\ -1 & -\bar{b} & +\bar{d} & BM_{ji} \\ - & - & -1 & BH_{ij} \\ - & - & +1 & BH_{ji} \end{bmatrix} \begin{bmatrix} X_1 \\ X_2 \\ X_3 \\ +1 \end{bmatrix} \quad (2-7)$$

thus,

$$\begin{bmatrix} M_{ij} \\ M_{ji} \\ H_{ij} \\ H_{ji} \end{bmatrix} = \begin{bmatrix} 1 & -\bar{a} & -\bar{c} & BM_{ij} \\ -1 & -\bar{b} & +\bar{d} & BM_{ji} \\ - & - & -1 & BH_{ij} \\ - & - & +1 & BH_{ji} \end{bmatrix} \begin{bmatrix} b_{11} & b_{12} & b_{13} & b_{14} & b_{15} \\ b_{21} & b_{22} & b_{23} & b_{24} & b_{25} \\ b_{31} & b_{32} & b_{33} & b_{34} & b_{35} \\ - & - & - & - & +1 \end{bmatrix} \begin{bmatrix} \theta_i \\ \theta_j \\ \Delta_{jix} \\ \Delta_{jiy} \\ +1 \end{bmatrix} \quad (2-7a)$$

Writing the final slope deflection matrix using the general slope deflection notation

$$\begin{bmatrix} M_{ij} \\ M_{ji} \\ H_{ij} \\ H_{ji} \end{bmatrix} = \begin{bmatrix} K_{ij} & C_{ji}K_{ji} & S_{ij}(x) & S_{ij}(y) & FM_{ij}(L) \\ C_{ij}K_{ij} & K_{ji} & S_{ji}(x) & S_{ji}(y) & FM_{ji}(L) \\ E_{ij} & B_{ji}E_{ji} & T_{ij}(x) & T_{ij}(y) & FH_{ij}(L) \\ B_{ij}E_{ij} & E_{ji} & T_{ji}(x) & T_{ji}(y) & FH_{ji}(L) \end{bmatrix} \begin{bmatrix} \theta_i \\ \theta_j \\ \Delta_{ijx} \\ \Delta_{ijy} \\ +1 \end{bmatrix} \quad (2-8)$$

is obtained, where the submatrix of deformation coefficients

$$\begin{bmatrix} K_{ij} & C_{ji}K_{ji} & S_{ij}(x) & S_{ij}(y) \\ C_{ij}K_{ij} & K_{ji} & S_{ji}(x) & S_{ji}(y) \\ E_{ij} & B_{ji}E_{ji} & T_{ij}(x) & T_{ij}(y) \\ B_{ij}E_{ij} & E_{ji} & T_{ji}(x) & T_{ji}(y) \end{bmatrix}$$

is denoted as the stiffness matrix, and the elements are defined and illustrated in Section (2-4).

2-3. Elastic Center

The elastic center is defined as the point at which

$$\begin{aligned} a_{12} &= a_{21} = 0 \\ a_{13} &= a_{31} = 0. \end{aligned}$$

These two relations completely specify the two coordinates necessary to locate the elastic center.

If the elastic center axes are rotated so that they coincide with the principal axes of the structure, $a_{23} = a_{32}$ can be eliminated. It is felt that this effort is not too practical for the general case and is not shown here.

From Fig. 2-3, it is seen that the unit horizontal force $X_3 = 1$ can be transferred to the bottom chord of the truss by replacing it by a unit horizontal force and a moment \bar{f} at the bottom chord (Fig. 2-4).

A new influence value γ' is introduced such that

$$\gamma_n = \gamma_n' + \bar{f} \alpha_n$$

where

$$\gamma_n' = \text{Normal force in member } n \text{ due to a unit horizontal applied at the bottom chord.}$$

Since $a_{13} = \sum_n \alpha_n \gamma_n \lambda_n = 0$, the vertical distance from

the bottom chord to the elastic center is

$$\bar{f} = - \frac{\sum_n \alpha_n \gamma_n' \lambda_n}{\sum_n \alpha_n^2 \lambda_n} \quad (2-9)$$

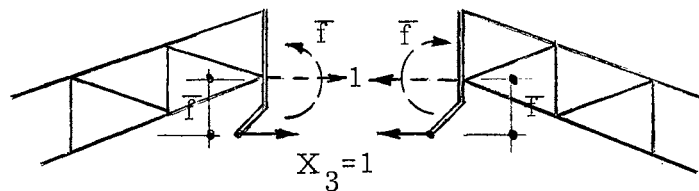

Fig. 2-4

Transfer of Horizontal Force

Also, the unit vertical force at the elastic center is transferred to the split in the structure by replacing it by a unit vertical force and a moment \bar{e} at the origin of the rigid arm (Fig. 2-5). Another influence value β' is introduced such that

$$\beta_n = \beta_n' + \bar{e} \alpha_n$$

where

β' = Normal force in member n due to a unit vertical force applied at the split in the structure.

Since

$$a_{12} = \sum_n \alpha_n \beta_n \lambda_n = 0 ,$$

the horizontal distance from the split in the structure to the elastic center is

$$\bar{e} = - \frac{\sum_n \alpha_n \beta_n' \lambda_n}{\sum_n \alpha_n^2 \lambda_n} \quad (2-10)$$

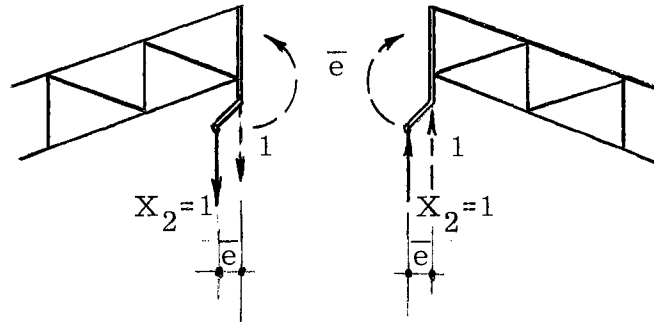

Fig. 2-5

Transfer of Vertical Force

Knowing the values of \bar{e} and \bar{f} , the dimensions \bar{a} , \bar{b} , \bar{c} , \bar{d} can be determined immediately.

2-4. Physical Interpretations and Definitions

The necessary constants for evaluating the stiffness matrix for a truss element of general shape are defined and illustrated in part A of this section. Also, the elements of the stiffness matrix are defined and illustrated in part B of this section. It is believed that an understanding of the physical significance of these constants will greatly enhance their evaluation and application.

A. Elastic Constants and Load Functions

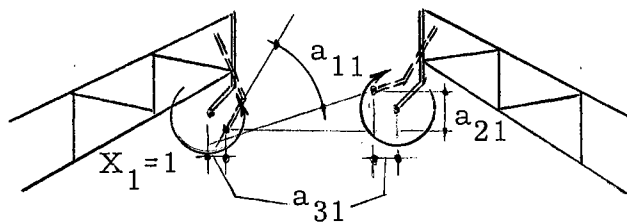

Fig. 2-6

Deformations Due to $X_1 = 1$

(1) The angular flexibility (a_{11}): is the relative angle change of the basic structure at the elastic center due to a unit moment applied at the elastic center (Fig. 2-6)

$$a_{11} = \sum_n \alpha_n^2 \lambda_n \quad (2-11)$$

(2) The carry-over value (a_{21}): is the relative vertical displacement of the basic structure at the elastic center due to a unit moment applied at the elastic center (Fig. 2-6)

$$a_{21} = \sum_n \beta_n \alpha_n \lambda_n \quad (2-12)$$

By the definition of the elastic center

$$a_{21} = 0 .$$

(3) The carry-over value (a_{31}): is the relative horizontal displacement of the basic structure at the elastic center due to a unit moment applied at the elastic center (Fig. 2-6)

$$a_{31} = \sum_n \gamma_n \alpha_n \lambda_n . \quad (2-13)$$

Also, by the definition of the elastic center

$$a_{31} = 0 .$$

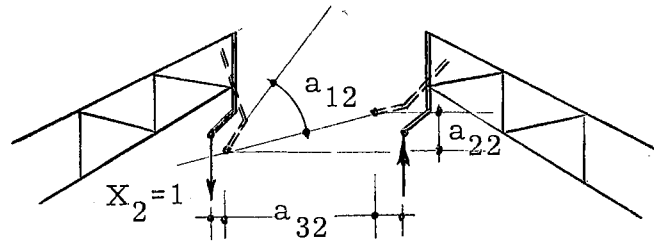

Fig. 2-7

Deformations Due to $X_2 = 1$

(4) The vertical linear flexibility (a_{22}): is the relative vertical displacement of the basic structure at the elastic center due to a unit vertical shearing force applied at the elastic center (Fig. 2-7)

$$a_{22} = \sum_n \beta_n^2 \lambda_n . \quad (2-14)$$

(5) The carry-over value (a_{12}): is the relative angle change of the basic structure at the elastic center due to a unit vertical shearing force applied at the elastic center (Fig. 2-7)

$$a_{12} = \sum_n \alpha_n \beta_n \lambda_n. \quad (2-15)$$

By the definition of the elastic center and Maxwell's reciprocal theorem

$$a_{12} = a_{21} = 0.$$

(6) The carry-over value (a_{32}): is the relative horizontal displacement of the basic structure at the elastic center due to a unit vertical shearing force applied at the elastic center (Fig. 2-7)

$$a_{32} = \sum_n \gamma_n \beta_n \lambda_n. \quad (2-16)$$

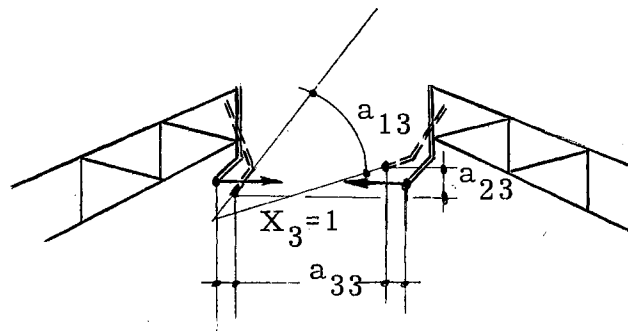

Fig. 2-8

Deformations Due to $X_3 = 1$

(7) The horizontal linear flexibility (a_{33}): is the relative horizontal displacement of the basic structure at the elastic center due to a unit horizontal thrust applied at the elastic center (Fig. 2-8)

$$a_{33} = \sum_n \gamma_n^2 \lambda_n. \quad (2-17)$$

(8) The carry-over value (a_{13}): is the relative angle change of the basic structure at the elastic center due to a unit horizontal thrust applied at the elastic center (Fig. 2-8)

$$a_{13} = \sum_n \alpha_n \gamma_n \lambda_n . \quad (2-18)$$

By the definition of the elastic center and Maxwell's reciprocal theorem

$$a_{13} = a_{31} = 0 .$$

(9) The carry-over value (a_{23}): is the relative vertical displacement of the basic structure at the elastic center due to a unit horizontal thrust applied at the elastic center

$$a_{23} = \sum_n \gamma_n \beta_n \lambda_n . \quad (2-19)$$

By Maxwell's reciprocal theorem

$$a_{23} = a_{32} ,$$

and if the structure is symmetrical

$$a_{23} = a_{32} = 0 .$$

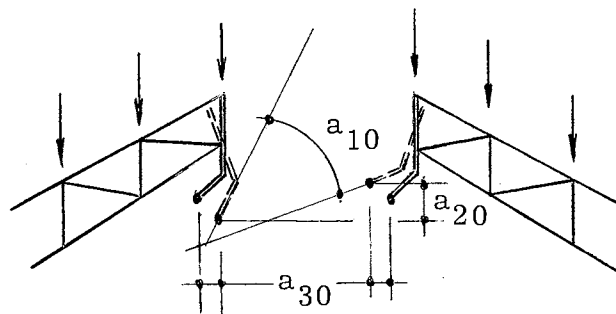

Fig. 2-9

Deformations Due to Loads

(10) The angular load function (a_{10}): is the relative angle change of the basic structure at the elastic center due to loads (Fig. 2-9)

$$a_{10} = \sum_n BN_n \alpha_n \lambda_n . \quad (2-20)$$

(11) The vertical linear load function (a_{20}): is the relative vertical displacement of the basic structure at the elastic center due to loads (Fig. 2-9)

$$a_{20} = \sum_n BN_n \beta_n \lambda_n . \quad (2-21)$$

(12) The horizontal linear load function (a_{30}): is the relative horizontal displacement of the basic structure at the elastic center due to loads (Fig. 2-9)

$$a_{30} = \sum_n BN_n \gamma_n \lambda_n . \quad (2-22)$$

B. Stiffness Constants and Fixed End Reactions

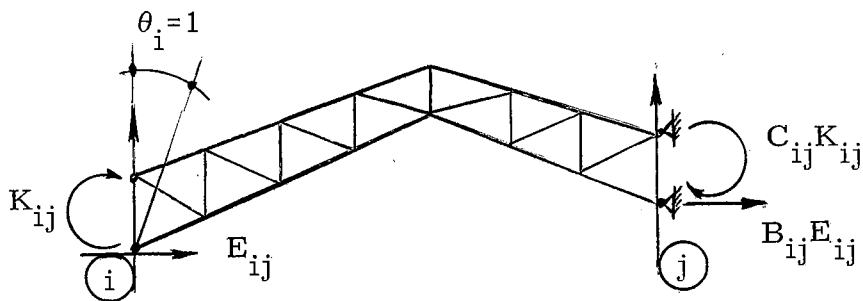

Fig. 2-10

Angular Stiffness Constants

(1) The angular stiffness factor (K_{ij}) : is the moment required to produce a unit rotation at the pinned end (i), end (j) being fixed (Fig. 2-10)

$$K_{ij} = + \frac{1}{a_{11}} + \bar{a}^2 \frac{a_{33}}{n} - 2\bar{a}\bar{c} \frac{a_{23}}{n} + \bar{c}^2 \frac{a_{22}}{n} \quad (2-23)$$

$$K_{ji} = + \frac{1}{a_{11}} + \bar{b}^2 \frac{a_{33}}{n} - 2\bar{b}\bar{d} \frac{a_{23}}{n} + \bar{d}^2 \frac{a_{22}}{n} .$$

Since for a symmetrical truss

$$\bar{a} = \bar{b} = \frac{L}{2}$$

$$\bar{c} = \bar{d}$$

$$a_{23} = a_{32} = 0$$

$$n = a_{22} a_{33}$$

then

$$K_{ij} = K_{ji} = + \frac{1}{a_{11}} + \frac{\bar{a}^2}{a_{22}} + \frac{\bar{c}^2}{a_{33}} \quad (2-23a)$$

(2) The angular-angular carry-over stiffness factor ($C_{ij}K_{ij}$): is the moment produced at the fixed end (j) due to a unit rotation at the pinned end (i) (Fig. 2-10)

$$C_{ij}K_{ij} = - \frac{1}{a_{11}} + \bar{a}\bar{b} \frac{a_{33}}{n} - \bar{b}\bar{c} \frac{a_{23}}{n} + \bar{a}\bar{d} \frac{a_{32}}{n} - \bar{c}\bar{d} \frac{a_{22}}{n} \quad (2-24)$$

$$C_{ji}K_{ji} = - \frac{1}{a_{11}} + \bar{a}\bar{b} \frac{a_{33}}{n} + \bar{a}\bar{d} \frac{a_{23}}{n} - \bar{b}\bar{c} \frac{a_{32}}{n} - \bar{c}\bar{d} \frac{a_{22}}{n} .$$

For a symmetrical truss

$$C_{ij}K_{ij} = C_{ji}K_{ji} = - \frac{1}{a_{11}} + \frac{\bar{a}^2}{a_{22}} - \frac{\bar{c}^2}{a_{33}} \quad (2-24a)$$

(3) The angular-horizontal linear carry-over stiffness factor

(E_{ij}) : is the horizontal thrust required at end (i) to maintain zero relative horizontal displacement of ends (i) and (j) due to a unit rotation at end (i), end (j) being fixed against rotation (Fig. 2-10)

$$E_{ij} = + \bar{c} \frac{a_{22}}{n} - \bar{a} \frac{a_{32}}{n} \quad (2-25)$$

$$E_{ji} = + \bar{d} \frac{a_{22}}{n} + \bar{b} \frac{a_{32}}{n} .$$

For a symmetrical truss

$$E_{ij} = E_{ji} = + \frac{\bar{c}}{a_{33}} . \quad (2-25a)$$

It is evident from Fig. 2-10 that the thrust carry-over factor

$$B_{ij} = B_{ji} = -1 .$$

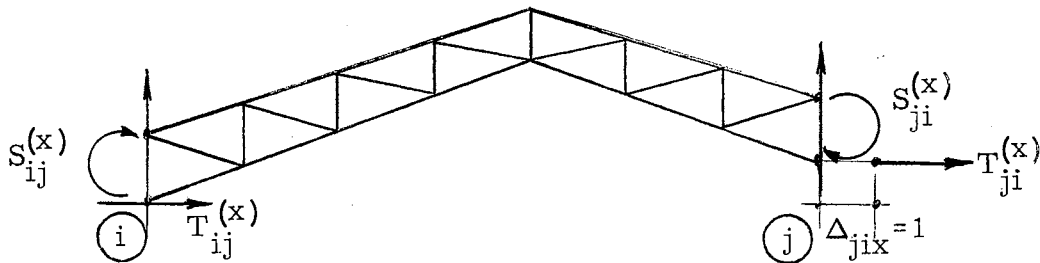

Fig. 2-11

Horizontal Linear Stiffness Constants

(4) The horizontal linear stiffness factor $(T_{ij}^{(x)})$: is the horizontal thrust at (i) required to produce a unit relative horizontal displacement of the ends (i) and (j), both ends being fixed against rotation (Fig. 2-11)

$$T_{ij}^{(x)} = - T_{ji}^{(x)} = - \frac{a_{22}}{n} . \quad (2-26)$$

For a symmetrical truss

$$T_{ij}^{(x)} = - T_{ji}^{(x)} = - \frac{1}{a_{33}} . \quad (2-26a)$$

(5) The horizontal linear-angular carry-over stiffness factor

$(S_{ij}^{(x)})$: is the moment required to maintain zero rotation at end (i) due to a unit relative horizontal displacement of the ends (i) and (j), end (j) being fixed against rotation (Fig. 2-11)

$$S_{ij}^{(x)} = - \bar{c} \frac{a_{22}}{n} + \bar{a} \frac{a_{23}}{n} \quad (2-27)$$

$$S_{ji}^{(x)} = + \bar{d} \frac{a_{22}}{n} + \bar{b} \frac{a_{23}}{n} .$$

For a symmetrical truss

$$S_{ij}^{(x)} = - S_{ji}^{(x)} = - \frac{\bar{c}}{a_{33}} . \quad (2-27a)$$

From Maxwell's reciprocal theorem

$$S_{ij}^{(x)} = - E_{ij}$$

$$S_{ji}^{(x)} = + E_{ji}$$

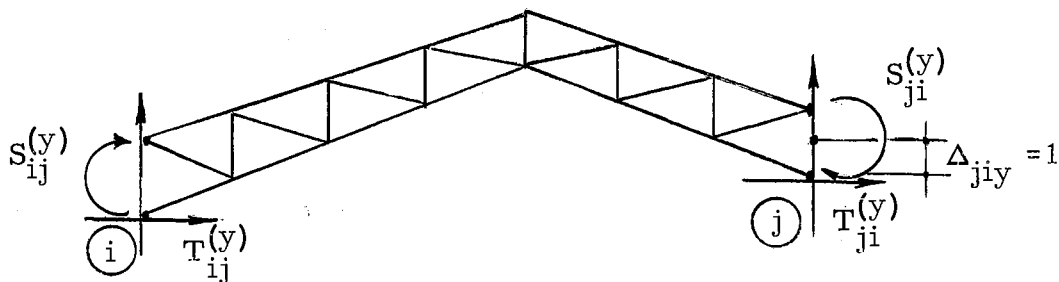

Fig. 2-12

Vertical Linear Stiffness Constants

(6) The vertical linear-horizontal linear carry-over stiffness

factor $(T_{ij}^{(y)})$: is the horizontal thrust at end (i) required to maintain zero relative horizontal displacement of ends (i) and (j) due to a unit

relative vertical displacement of ends (i) and (j) (Fig. 2-12)

$$T_{ij}^{(y)} = - T_{ji}^{(y)} = - \frac{a_{32}}{n} . \quad (2-28)$$

For a symmetrical truss

$$T_{ij}^{(y)} = - T_{ji}^{(y)} = 0 \quad (2-28a)$$

(7) The vertical linear-angular carry-over stiffness factor ($S_{ij}^{(y)}$): is the moment at end (i) required to maintain zero rotation at end (i) due to a unit relative vertical displacement of ends (i) and (j), end (i) being fixed against rotation (Fig. 2-12)

$$S_{ij}^{(y)} = + \bar{a} \frac{a_{33}}{n} - \bar{c} \frac{a_{32}}{n} \quad (2-29)$$

$$S_{ji}^{(y)} = + \bar{b} \frac{a_{33}}{n} + \bar{d} \frac{a_{32}}{n} .$$

For a symmetrical truss

$$S_{ij}^{(y)} = S_{ji}^{(y)} = + \frac{\bar{a}}{a_{22}} . \quad (2-29a)$$

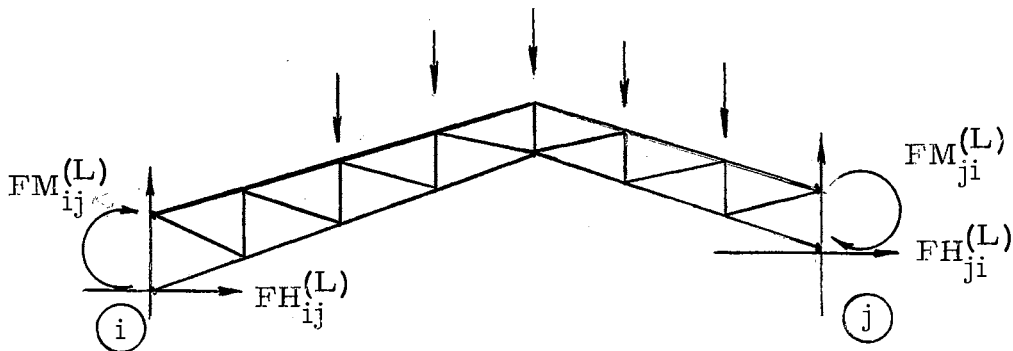

Fig. 2-13

Fixed End Reactions

(8) The fixed end moment due to loads ($FM_{ij}^{(L)}$): is the moment at (i) required to maintain zero rotation at end (i) due to loads, both ends being fixed (Fig. 2-13)

$$FM_{ij}^{(L)} = -\frac{a_{10}}{a_{11}} - \left(-\bar{a}\frac{a_{33}}{n} + \bar{c}\frac{a_{32}}{n}\right)a_{20} - \left(-\bar{c}\frac{a_{22}}{n} + \bar{a}\frac{a_{23}}{n}\right)a_{30} + BM_{ij} \quad (2-30)$$

$$FM_{ji}^{(L)} = +\frac{a_{10}}{a_{11}} + \left(\bar{b}\frac{a_{33}}{n} + \bar{d}\frac{a_{32}}{n}\right)a_{20} - \left(\bar{d}\frac{a_{22}}{n} + \bar{b}\frac{a_{23}}{n}\right)a_{30} + BM_{ji} .$$

For a symmetrical truss

$$FM_{ij}^{(L)} = -\frac{a_{10}}{a_{11}} + \frac{\bar{a}}{a_{22}}a_{20} + \frac{\bar{c}}{a_{33}}a_{30} + BM_{ij} \quad (2-30a)$$

$$FM_{ji}^{(L)} = +\frac{a_{10}}{a_{11}} + \frac{\bar{a}}{a_{22}}a_{20} - \frac{\bar{c}}{a_{33}}a_{30} + BM_{ji} .$$

(9) The fixed end thrust due to loads ($FH_{ij}^{(L)}$): is the horizontal thrust at end (i) required to maintain zero relative horizontal displacement of ends (i) and (j) due to loads, both ends being fixed (Fig. 2-13)

$$FH_{ij}^{(L)} = -FH_{ji}^{(L)} = \frac{a_{22}}{n}a_{30} - \frac{a_{32}}{n}a_{20} + BH_{ij} . \quad (2-31)$$

For a symmetrical truss

$$FH_{ij}^{(L)} = -FH_{ji}^{(L)} = +\frac{a_{30}}{a_{33}} + BH_{ij} . \quad (2-31a)$$

CHAPTER III
MODIFIED DEFORMATION EQUATIONS FOR
PRISMATIC COLUMNS

3-1. General

It is necessary to modify the deformation equations for the columns in order to have compatibility at the connection of the truss to the column. In the deformation equations for the truss, the deformations were taken as the linear displacements of the bottom chord and the rotation of the line through the top and bottom joints at the end of the truss. In order to have compatibility of deformations at the truss-column connection, the deformation of the column must be defined in terms of the same displacements and rotation.

Two typical cases exist: A. column fixed at the base, B. column pinned at the base. These two cases are considered in the following section.

3-2. Derivation

A typical intermediate column $\bar{j}\bar{o}$ of the structure, with reactive forces from the adjoining trusses acting on it is shown (Fig. 3-1a). Due to these forces, joint (j) will deflect horizontally a distance Δ_{jx} , while the top joint (j') will displace an additional amount Δ'_{jx} (Fig. 3-1b). Consequently the column $\bar{j}\bar{o}$ has displacements Δ_{jx} and $\Delta_{jx} + \Delta'_{jx}$ at joints (j) and (j') , respectively. The column is continuous through joint (j) with a slope ϕ_j , hence, it is necessary to formulate the column

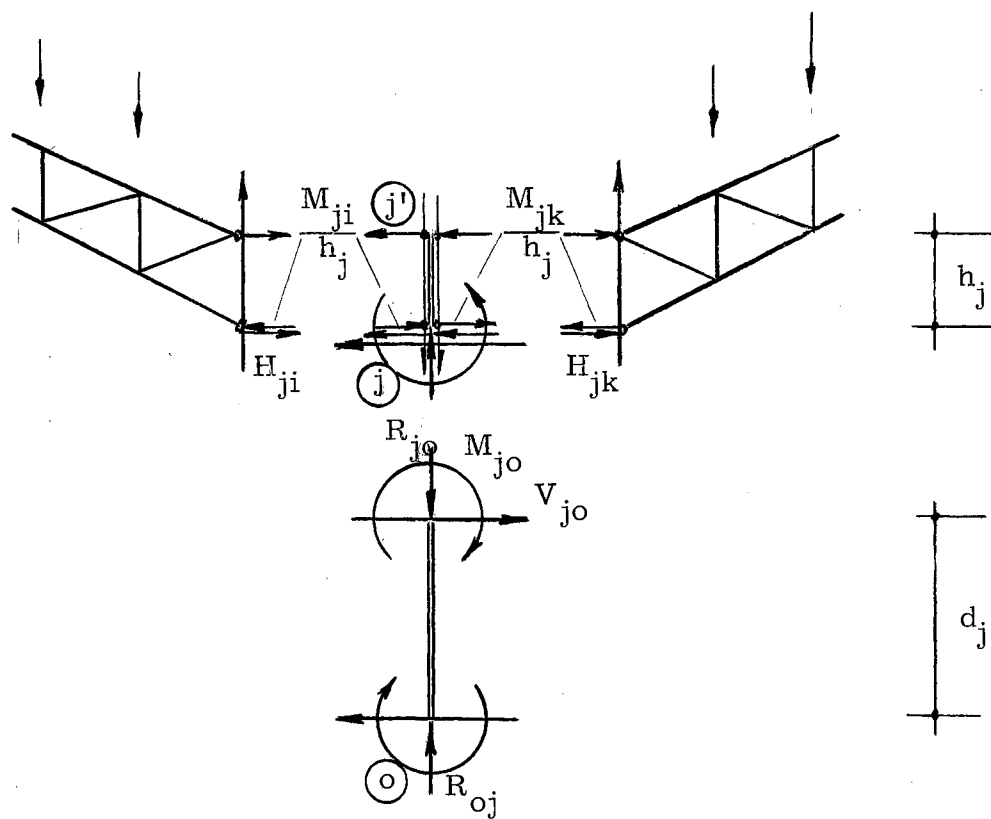

(a) State of Equilibrium

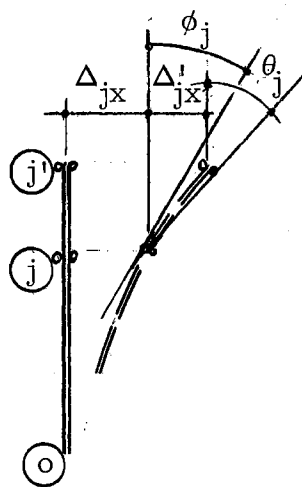

(b) State of Deformation

Fig. 3-1

Typical Intermediate Column

deformations Δ'_{jx} , ϕ_j in terms of the defining deformations for the truss Δ_{jx} , θ_j . One deformation relation is written from the geometry (Fig. 3-1b)

$$\theta_j = \frac{\Delta'_{jx}}{h_j} \quad (3-1)$$

A second condition is obtained from the equilibrium of column moments at joint \textcircled{j} .

A. Fixed End Base

The slope deflection equations for a prismatic column fixed at \textcircled{o} are

$$\begin{aligned} M_{oj} &= \frac{2EI_j}{d_j} \phi_j - \frac{6EI_j}{d_j^2} \Delta_{jx} \\ M_{jo} &= \frac{4EI_j}{d_j} \phi_j - \frac{6EI_j}{d_j} \Delta_{jx} \\ M_{jj'} &= \frac{3EI_j}{h_j} \phi_j - \frac{3EI_j}{h_j^2} \Delta'_{jx} \end{aligned} \quad (3-2)$$

$$M_{j'j} = 0$$

from the equilibrium of moments at joint \textcircled{j}

$$\sum M_j = 0, \quad M_{jo} + M_{jj'} = 0$$

thus,

$$\left(\frac{4EI_j}{d_j} + \frac{3EI_j}{h_j} \right) \phi_j - \frac{6EI_j}{d_j^2} \Delta_{jx} - \frac{3EI_j}{h_j^2} \Delta'_{jx} = 0$$

or solving for ϕ_j

$$\phi_j = \frac{\frac{6}{d_j^2} \Delta_{jx} + \frac{3}{h_j^2} \Delta'_{jx}}{\frac{4}{d_j} + \frac{3}{h_j}} \quad (3-3)$$

Substituting the relation expressed by Eq. (3-1), and denoting $\mu_j = \frac{h_j}{d_j}$,

$$\phi_j = \left(\frac{1}{1 + \frac{4}{3} \mu_j} \right) \theta_j + \frac{1}{d_j} \left(\frac{2 \mu_j}{1 + \frac{4}{3} \mu_j} \right) \Delta_{jx} \quad (3-3a)$$

Substituting Eq. (3-3a) into Eq's. (3-3), the modified slope deflection equations are

$$M_{oj} = \frac{2EI_j}{d_j} \left(\frac{1}{1 + \frac{4}{3} \mu_j} \right) \theta_j - \frac{6EI_j}{d_j^2} \left(\frac{1 + \frac{2}{3} \mu_j}{1 + \frac{4}{3} \mu_j} \right) \Delta_{jx} \quad (3-4)$$

$$M_{jo} = \frac{4EI_j}{d_j} \left(\frac{1}{1 + \frac{4}{3} \mu_j} \right) \theta_j - \frac{6EI_j}{d_j^2} \left(\frac{1}{1 + \frac{4}{3} \mu_j} \right) \Delta_{jx}$$

$$M_{jj'} = - M_{jo}$$

$$M_{j'j} = 0$$

B. Pinned End Base:

The slope deflection equations for a pinned-end prismatic column are

$$M_{oj} = 0$$

$$M_{jo} = \frac{3EI_j}{d_j} \phi_j - \frac{3EI_j}{d_j^2} \Delta_{jx} \quad (3-5)$$

$$M_{jj'} = \frac{3EI_j}{d_j} \phi_j - \frac{3EI_j}{h_j^2} \Delta'_{jx}$$

$$M_{j'j} = 0$$

From the equilibrium of joint (j)

$$\sum M_j = 0, \quad M_{jo} + M_{jj'} = 0$$

thus,

$$\left(\frac{3EI_j}{d_j} + \frac{3EI_j}{h_j} \right) \phi_j - \frac{3EI_j}{d_j^2} \Delta_{jx} - \frac{3EI_j}{h_j^2} \Delta'_{jx} = 0$$

or solving for ϕ_j

$$\phi_j = \frac{\frac{1}{d_j} \Delta_{jx} + \frac{1}{h_j} \Delta'_{jx}}{\frac{1}{d_j} + \frac{1}{h_j}} \quad (3-6)$$

Substituting Eq. (3-1) and denoting $\mu_j = \frac{h_j}{d_j}$, Eq. (3-6) becomes

$$\phi_j = \left(\frac{1}{1 + \mu_j} \right) \phi_j + \frac{1}{d_j} \left(\frac{\mu_j}{1 + \mu_j} \right) \Delta_{jx} \quad (3-6a)$$

Substituting Eq. (3-6a) into Eq's. (3-5), the modified slope deflection equations are

$$M_{oj'} = 0$$

$$M_{jo} = \frac{3EI_j}{d_j} \left(\frac{1}{1 + \mu_j} \right) \phi_j - \frac{3EI_j}{d_j^2} \left(\frac{1}{1 + \mu_j} \right) \Delta_{jx} \quad (3-7)$$

$$M_{jj'} = - M_{jo}$$

$$M_{j'j} = 0$$

These modified slope deflection equations for prismatic columns combined with the slope deflection equations for the truss elements enables the analyst to obtain a direct solution for continuous truss frames of general shape by the method of slope deflection.

CHAPTER IV

MOMENT DISTRIBUTION

4-1. General

The analysis of continuous truss frames by the method of slope deflection might lead to the necessity of solving a large number of simultaneous equations. The solution of these equations is quite laborious and tedious if the number is sufficiently large. Thus, unless a computer is available, it is desirable to have a numerical solution which at least will reduce the number of simultaneous equations to solve. The method of moment distribution is one that can be applied to truss frames in the same manner as for frames composed of solid members.

It is necessary to redefine the linear displacement terms in the general slope deflection equations (Eq's. 2- 8). These terms are denoted as fixed end reactions due to displacement, thus:

(a) Fixed End Moments:

(i) Due to Δ_x

$$FM_{ij}^{(x)} = S_{ij}^{(x)} \Delta_{jix} \quad (4-1)$$

$$FM_{ji}^{(y)} = S_{ji}^{(x)} \Delta_{jix}$$

(ii) Due to Δ_y

$$FM_{ij}^{(y)} = S_{ij}^{(y)} \Delta_{jiy} \quad (4-2)$$

$$FM_{ji}^{(y)} = S_{ji}^{(y)} \Delta_{jiy}$$

(b) Fixed End Thrusts:

(i) Due to Δ_x

$$\begin{aligned} FH_{ij}^{(x)} &= T_{ij}^{(x)} \Delta_{jix} \\ FH_{ji}^{(x)} &= T_{ji}^{(x)} \Delta_{jix} \end{aligned} \quad (4-3)$$

(ii) Due to Δ_y

$$\begin{aligned} FH_{ij}^{(y)} &= T_{ij}^{(y)} \Delta_{jiy} \\ FH_{ji}^{(y)} &= T_{ji}^{(y)} \Delta_{jiy} \end{aligned} \quad (4-4)$$

Since the moment distribution procedure eliminates the rotations (θ 's), it is necessary to modify the thrusts due to rotation.

4-2. Modification

Denoting the end reactions due to rotation as rotational moments and thrusts, respectively, and introducing the following notation:

(a) Rotational Moments:

$$\begin{aligned} RM_{ij} &= K_{ij} \theta_i + C_{ji} K_{ji} \theta_j \\ RM_{ji} &= K_{ji} \theta_j + C_{ij} K_{ij} \theta_i \end{aligned} \quad (4-5)$$

(b) Rotational Thrusts:

$$\begin{aligned} RH_{ij} &= E_{ij} \theta_i + B_{ji} E_{ji} \theta_j \\ RH_{ji} &= E_{ji} \theta_j + B_{ij} E_{ij} \theta_i \end{aligned} \quad (4-6)$$

the slope deflection equations (Eq's 2-8) become

$$\begin{bmatrix} M_{ij} \\ M_{ji} \\ H_{ij} \\ H_{ji} \end{bmatrix} = \begin{bmatrix} RM_{ij} & FM_{ij}^{(x)} & FM_{ij}^{(y)} & FM_{ij}^{(L)} \\ RM_{ji} & FM_{ji}^{(x)} & FM_{ji}^{(y)} & FM_{ji}^{(L)} \\ RH_{ij} & FH_{ij}^{(x)} & FH_{ij}^{(y)} & FH_{ij}^{(L)} \\ RH_{ji} & FH_{ji}^{(x)} & FH_{ji}^{(y)} & FH_{ji}^{(L)} \end{bmatrix} \begin{bmatrix} +1 \\ +1 \\ +1 \\ +1 \end{bmatrix} \quad (4-7)$$

Since the rotational thrusts (Eq's 4-6) are expressed in terms of rotations (θ 's), it is necessary to eliminate these θ 's utilizing Eq's (4-5). Solving for the rotations from Eq's (4-5)

$$\theta_i = \frac{RM_{ij} - C_{ji} RM_{ji}}{K_{ij} (1 - C_{ij} C_{ji})} \quad (4-8)$$

$$\theta_j = \frac{RM_{ji} - C_{ij} RM_{ij}}{K_{ji} (1 - C_{ij} C_{ji})}$$

denoting

$$K'_{ij} = K_{ij} (1 - C_{ij} C_{ji})$$

$$K'_{ji} = K_{ji} (1 - C_{ij} C_{ji})$$

and since

$$B_{ij} = B_{ji} = -1 ,$$

then by substituting Eq's (4-8) into Eq's. (4-6), the rotational thrusts become

$$\begin{aligned} RH_{ij} &= \rho_{ij} RM_{ij} - \rho_{ji} RM_{ji} \\ RH_{ji} &= \rho_{ji} RM_{ji} - \rho_{ij} RM_{ij} \end{aligned} \quad (4-9)$$

where

$$\rho_{ij} = \frac{E_{ij}}{K'_{ij}} + \frac{C_{ij} E_{ji}}{K'_{ji}} \quad (4-10)$$

$$\rho_{ji} = \frac{C_{ji} E_{ij}}{K'_{ij}} + \frac{E_{ji}}{K'_{ji}} .$$

ρ_{ij} is known as the thrust induction factor and is defined as the thrust developed at end (i) due to a unit rotational moment applied at (i) with the other end (j) free to rotate ($RM_{ji} = 0$). ρ_{ji} is similarly defined. For a symmetrical structure, Eq's. (4-10) become

$$\rho_{ij} = \rho_{ji} = \frac{E_{ij}}{K'_{ij}} (1 + C_{ij}) = \frac{E_{ij}}{K_{ij} (1 - C_{ij})} \quad (4-10a)$$

4-3. Procedure

Using the method of moment distribution, the following procedure is applied

1. Determine stiffness constants and thrust induction factors (Eq's. 2-23 to 29; 3-4, or 3-7; 4-10). From these the carry-over factors

$$C_{ij} = \frac{C_{ij} K_{ij}}{K_{ij}} ,$$

and the distribution factors

$$D_{ji} = \frac{K_{ji}}{\sum K_j}$$

can be obtained.

2. Compute fixed end reactions
 - (a) Due to loads (Eq's. 2-30, 31)
 - (b) Due to Δ_x (Eq's. 4-1, 3)
 - (c) Due to Δ_y (Eq's. 4-2, 4)

3. Using moment distribution procedure, calculate
 - (a) Final moments due to each unbalanced fixed end moment.
 - (b) Rotational moments RM's which are the difference between the corresponding fixed end moments and final moments.
 4. Compute the rotational thrusts in terms of rotational moments (Eq's. 4-9).
 5. Formulate shear equilibrium equations and solve simultaneously for the unknown displacements or their equivalents.
 6. Substitute the computed deformation equivalents into the moment distribution tables and compute the final end moments, thrusts, and shears.
 7. Check for equilibrium of moments and forces at the joints.
-

CHAPTER V

APPLICATION

5-1. General

The method of slope deflection is used as the tool of analysis for the numerical example included in Sec. 5-3. A two-span truss frame is analyzed by the "exact" slope deflection method presented in this thesis and compared with the "approximate" method commonly used, where an average column length is assumed.

5-2. Procedure

The following procedure is used in the slope deflection analysis.

1. Determine the elastic constants and load functions (Eq's. 2-11, 14, 16, 17, 19 to 22)
2. From these constants (step 1), calculate the stiffness constants and fixed end reactions (Eq's. 2-23 to 31).
3. Formulate the slope deflection matrix (Eq's. 2-8) for the truss and (Eq's. 3-4 or 3-5) for columns depending on the fixing condition of the column base. Also include the column shear

$$V_{jo} = - \frac{M_{jo} + M_{oj}}{d_j} + BV_{jo} .$$

4. Write a joint moment equilibrium equation for each independently rotating joint.

5. Write a joint shear equilibrium equation for each independently translating joint.
6. Formulate the equilibrium matrix from steps 4 and 5.
7. Solve for the unknown deformations, θ 's and Δ 's.
8. Substitute these deformations into the slope deflection matrix (step 3) and compute the final value of the moments, thrusts, and shears.
9. Check for equilibrium.

5-3. Numerical Example

A two-span truss frame with prismatic columns and dimensions as shown in Fig. 5-1 is analyzed by the slope deflection method. The modulus of elasticity, E , is assumed to be the same for the entire structure, and the moment of inertia for all the columns, $I_{col.}$, is considered to be constant. The analysis is made for a lateral concentrated load of 10^k , applied at the top chord.

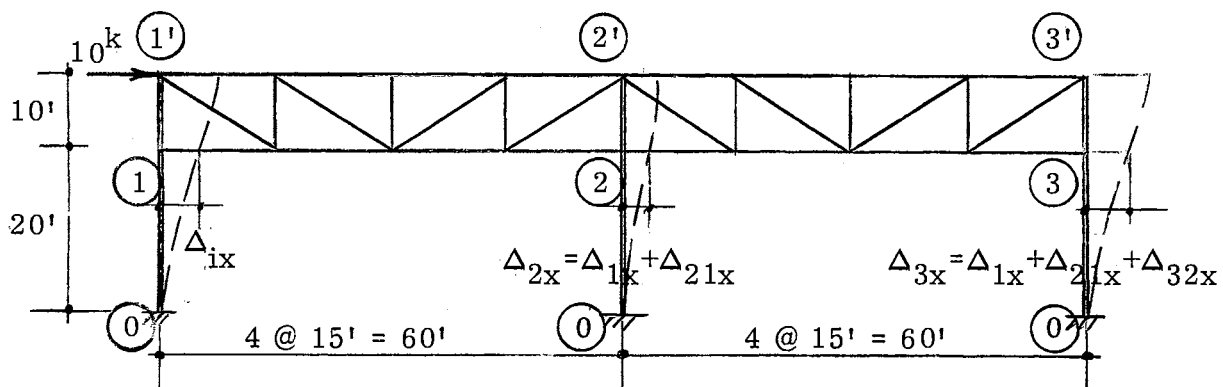

Fig. 5-1

Two-Span Truss Frame

The properties of the structure are:

$$A_n = 14.4 \text{ in.}^2 = 0.1 \text{ ft.}^2$$

$$I_{\text{col.}} = 500 \text{ in.}^4 = 0.0241 \text{ ft.}^4$$

$$\lambda_n = \frac{d_n}{A_n E} = \frac{d_n}{0.1E} = \frac{10 d_n}{E}$$

$$\lambda'_n = E \lambda_n = 10 d_n .$$

Due to the fact that the structure is symmetrical and has equal number of top and bottom members having the same area and placed at constant depth apart, it consequently becomes evident that the elastic center will fall at mid-span and mid-depth of the truss element.

A. "Exact" Analysis

1. Elastic Constants and Load Functions

The elastic properties of the truss are computed using the basic structure (Fig. 5-2). Unit redundants are applied at the elastic center, and the results obtained are recorded as shown in Table 5-1. Since the structure is symmetrical, only the left half is included in Table 5-1. The total elastic constants are obtained by doubling the results in this table. Also, since there are no intermediate loads on the truss, all load functions are zero.

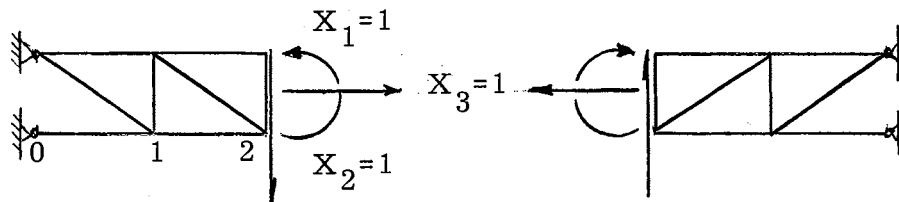

Fig. 5-2

Basic Structure

n		λ'_n	α_n	β_n	γ_n	BN_n	a'_{11}	a'_{22}	a'_{33}	a'_{10}	a'_{20}	a'_{30}
							$\Sigma \alpha_n^2 \lambda'_n$	$\Sigma \beta_n^2 \lambda'_n$	$\Sigma \gamma_n^2 \lambda'_n$	$\Sigma BN_n \alpha_n \lambda'_n$	$\Sigma BN_n \beta_n \lambda'_n$	$\Sigma BN_n \gamma_n \lambda'_n$
TOP	1	150	-0.100	+1.500	+0.500	-	+1.500	+ 337.50	+ 37.5	-	-	-
	2	150	-0.100	-	+0.500	-	+1.500	-	+ 37.5	-	-	-
BTM	1	150	+0.100	-3.000	+0.500	-	+1.500	+1350.00	+ 37.5	-	-	-
	2	150	+0.100	-1.500	+0.500	-	+1.500	+ 337.50	+ 37.5	-	-	-
DGL	1	180.5	-	+1.805	-	-	-	+ 583.07	-	-	-	-
	2	180.5	-	+1.805	-	-	-	+ 583.07	-	-	-	-
VTL	1	100	-	-1.000	-	-	-	+ 100.00	-	-	-	-
	2	100	-	-	-	-	-	-	-	-	-	-
Σ							+6.000	+3291.14	+150.0	-	-	-

Table 5-1
Elastic Constants and Load Functions

For the entire span

$$a'_{11} = + 12.000$$

$$a'_{22} = + 6582.280$$

$$a'_{33} = + 300.000$$

$$a'_{23} = a'_{32} = 0 \text{ (symmetry)}$$

$$a'_{10} = a'_{20} = a'_{30} = 0,$$

where

$$a' = aE$$

2. Stiffness Constants and Fixed End Reactions

Stiffness Constants: from Eq's. 2-23a, 24a

$$K_{12} = K_{21} = \left(+ \frac{1}{a'_{11}} + \frac{\bar{a}^2}{a'_{22}} + \frac{\bar{c}^2}{a'_{33}} \right) E = + 0.3033E$$

$$C_{12}K_{12} = C_{21}K_{21} = \left(- \frac{1}{a'_{11}} + \frac{\bar{a}^2}{a'_{22}} - \frac{\bar{c}^2}{a'_{33}} \right) E = - 0.0299E$$

from Eq's. 2-25a

$$E_{12} = + E_{21} = \left(+ \frac{\bar{c}}{a'_{33}} \right) E = + 0.0167E$$

from Eq's. 2-26a

$$T_{12}^{(x)} = - T_{21}^{(x)} = \left(- \frac{1}{a'_{33}} \right) E = - 0.0033E$$

from Eq's. 2-27a

$$S_{12}^{(x)} = - S_{21}^{(x)} = \left(- \frac{\bar{c}}{a'_{33}} \right) E = - 0.0167E.$$

Since there is no vertical displacement, the vertical linear stiffness constants are not needed.

Fixed End Reactions:

Since all load functions are zero, the fixed end reactions are zero.

3. Slope Deflection Matrix

Writing Eq. 2-8 for all elements in the structure the following matrices are obtained:

For truss $\overline{12}$

$$\begin{bmatrix} M_{12} \\ M_{21} \\ H_{12} \\ H_{21} \end{bmatrix} = \begin{bmatrix} +0.3033 & -0.0299 & -0.0167 \\ -0.0299 & +0.3033 & +0.0167 \\ +0.0167 & -0.0167 & -0.0033 \\ -0.0167 & +0.0167 & +0.0033 \end{bmatrix} \begin{bmatrix} E\theta_1 \\ E\theta_2 \\ E\Delta_{21x} \end{bmatrix}$$

Similarly for truss $\overline{23}$

$$\begin{bmatrix} M_{23} \\ M_{32} \\ H_{23} \\ H_{32} \end{bmatrix} = \begin{bmatrix} +0.3033 & -0.0299 & -0.0167 \\ -0.0299 & +0.3033 & +0.0167 \\ +0.0167 & -0.0167 & -0.0033 \\ -0.0167 & +0.0167 & +0.0033 \end{bmatrix} \begin{bmatrix} E\theta_2 \\ E\theta_3 \\ E\Delta_{32x} \end{bmatrix}$$

For columns $\overline{10}$, $\overline{20}$, and $\overline{30}$

Moment Equations:

from Eq's. 3-4

$$M_{10} = +0.0029 E\theta_1 - 0.000217 E\Delta_{1x}$$

$$M_{20} = +0.0029 E\theta_2 - 0.000217 E (\Delta_{1x} + \Delta_{21x})$$

$$M_{30} = +0.0029 E\theta_3 - 0.000217 E (\Delta_{1x} + \Delta_{21x} + \Delta_{32x})$$

Shear Equations:

from step 3

$$V_{10} = -.000217 E \theta_1 + .000025 E \Delta_{1x}$$

$$V_{20} = -.000217 E \theta_2 + .000025 E (\Delta_{1x} + \Delta_{21x})$$

$$V_{30} = -.000217 E \theta_3 + .000025 E (\Delta_{1x} + \Delta_{21x} + \Delta_{32x})$$

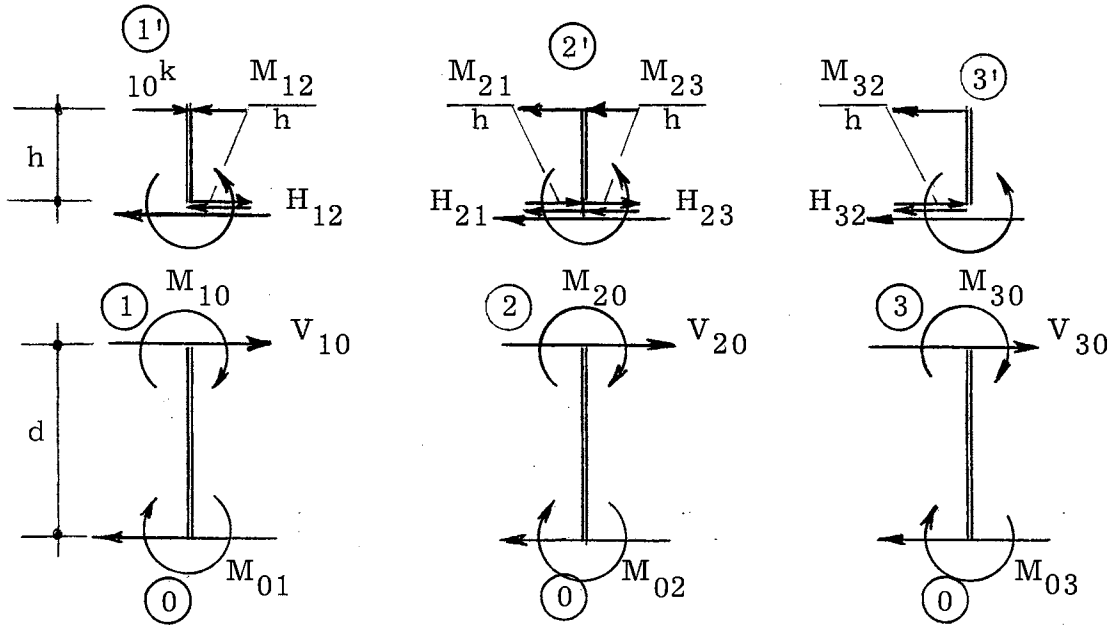

Fig. 5-3

Free Body Diagram

From the free body diagrams (Fig. 5-3), joint moment and shear equilibrium equations are written.

4. Joint Moment Equilibrium Equations

$$(i) \quad \Sigma M_1 = 0 ; \quad M_{12} + M_{10} = 10h$$

$$(ii) \quad \Sigma M_2 = 0 ; \quad M_{21} + M_{23} + M_{20} = 0$$

$$(iii) \quad \Sigma M_3 = 0 ; \quad M_{32} + M_{30} = 0$$

5. Joint Shear Equilibrium Equations

$$(i) \quad \Sigma F_{x1} = 0 ; \quad H_{12} + V_{10} = 10$$

$$(ii) \quad \Sigma F_{x2} = 0 ; \quad H_{21} + H_{23} + V_{20} = 0$$

$$(iii) \quad \Sigma F_{x3} = 0 ; \quad H_{32} + V_{30} = 0$$

6. Equilibrium Matrix

Writing the previous equilibrium equations in matrix form, the following equilibrium matrix is obtained

$$\begin{bmatrix} +.306200 & -.029700 & - & -.000217 & -.016700 & - \\ -.029700 & +.609500 & -.029900 & -.000217 & +.016483 & -.016700 \\ - & -.029900 & +.306200 & -.000217 & -.000217 & +.016483 \\ +.016483 & -.016700 & - & +.000025 & -.003300 & - \\ -.016700 & +.033180 & -.016700 & +.000025 & +.003325 & -.003300 \\ - & -.016700 & +.016483 & +.000025 & +.000025 & +.003325 \end{bmatrix} \begin{bmatrix} E\theta_1 \\ E\theta_2 \\ E\theta_3 \\ E\Delta_{1x} \\ E\Delta_{21x} \\ E\Delta_{32x} \end{bmatrix} = \begin{bmatrix} 100 \\ - \\ - \\ 10 \\ - \\ - \end{bmatrix} \quad (5-1)$$

7. The unknown deformations θ 's and Δ 's are obtained by means of the IBM 650 computer, and the results tabulated in Table 5-2.

8. The deformations solved for in step 7 are substituted into the slope deflection matrix (step 3) and the final value of moments and thrust are again tabulated in Table 5-2.

B. "Approximate" Analysis

The same problem is solved by the usual "approximate" method in which the horizontal thrust is neglected thus eliminating the elastic shortening of the truss while the average length of the column is taken as $d_{avg} = 25$ ft. The following procedure is followed

1. Elastic Constants and Load Functions

These expressions are the same as in Part A, except that the influence values for $X_3 = 1$ are not needed.

2. Stiffness Constants

For truss:

$$K_{ij} = K_{ji} = \left(+\frac{1}{a'_{11}} + \frac{\bar{a}^2}{a'_{22}} \right) E = +.2200E$$

$$C_{ij}K_{ij} = C_{ji}K_{ji} = \left(-\frac{1}{a'_{11}} + \frac{\bar{a}^2}{a'_{22}} \right) E = +.0534E$$

The remaining stiffness factors are not required for the approximate solution and are thus eliminated.

3. Slope Deflection Matrix

For truss $\overline{12}$ and $\overline{23}$

$$\begin{bmatrix} M_{12} \\ M_{21} \\ M_{23} \\ M_{32} \end{bmatrix} = \begin{bmatrix} +.2200 & +.0534 & - \\ +.0534 & +.2200 & - \\ - & +.2200 & +.0534 \\ - & +.0534 & +.2200 \end{bmatrix} \begin{bmatrix} E\theta_1 \\ E\theta_2 \\ E\theta_3 \end{bmatrix}$$

For columns $\overline{10}$, $\overline{20}$ and $\overline{30}$

Moment Equations:

$$M_{10} = +.00386 E\theta_1 - .00023 E\Delta_{1x}$$

$$M_{20} = +.00386 E\theta_2 - .00023 E\Delta_{1x}$$

$$M_{30} = +.00386 E\theta_3 - .00023 E\Delta_{1x}$$

Shear Equations:

$$V_{10} = -.00023 E\theta_1 + .00002 E\Delta_{1x}$$

$$V_{20} = -.00023 E\theta_2 + .00002 E\Delta_{1x}$$

$$V_{30} = -.00023 E\theta_3 + .00002 E\Delta_{1x}$$

4. Joint Moment Equilibrium Equations

$$\Sigma M_1 = 0 ; \quad M_{12} + M_{10} = 50$$

$$\Sigma M_2 = 0 ; \quad M_{21} + M_{23} + M_{20} = 0$$

$$\Sigma M_3 = 0 ; \quad M_{32} + M_{30} = 0$$

5. Shear Equilibrium Equations

$$\Sigma F_x = 0 ; \quad V_{10} + V_{20} + V_{30} = 10$$

6. Equilibrium Matrix

$$\begin{bmatrix} +.22386 & +.05340 & - & -.00023 \\ +.05340 & +.44386 & +.05340 & -.00023 \\ - & +.05340 & +.22386 & -.00023 \\ -.00023 & -.00023 & -.00023 & +.00006 \end{bmatrix} \begin{bmatrix} E\theta_1 \\ E\theta_2 \\ E\theta_3 \\ E\Delta_{1x} \end{bmatrix} = \begin{bmatrix} 50 \\ - \\ - \\ 10 \end{bmatrix} \quad (5-2)$$

7. The unknown deformations θ 's and Δ are obtained by means of the IBM 650 computer and the results tabulated in Table 5-2.

8. The deformations solved for in step 7 are substituted into the slope deflection matrix (step 3) and the final value of moments and thrusts are again tabulated in Table 5-2.

The final solution of problem by both methods is obtained by inverting the equilibrium matrices (Eq's, 5-1, 2) by the IBM 650 computer, yielding the final answers as tabulated in Table 5-2.

	"Exact" Analysis	"Approx. " Analysis
$E\theta_1$	+ 424.205	+ 392.098
$E\theta_2$	+ 28.523	+ 20.043
$E\theta_3$	+ 199.574	+ 168.745
$E\Delta_{1x}$	+135861.986	+168893.401
$E\Delta_{21x}$	- 26.554	-
$E\Delta_{32x}$	- 1867.405	-
M_{10}	- 28.252	- 37.332
M_{12}	+ 128.252	+ 87.332
M_{21}	- 4.476	+ 25.347
M_{20}	- 29.393	- 38.768
M_{23}	+ 33.869	+ 13.420
M_{32}	+ 28.492	+ 38.194
M_{30}	- 28.492	- 38.194
M_{01}	- 38.649	- 38.089
M_{02}	- 39.215	- 38.807
M_{03}	- 38.427	- 38.520
$H_{12} = -H_{21}$	+ 6.696	+ 6.983
$H_{23} = -H_{32}$	+ 3.306	+ 3.069

Table 5-2

Comparison of Results

CHAPTER VI

SUMMARY AND CONCLUSION

6-1. Summary

The "exact" application of the slope deflection method of analysis of truss frames is outlined in the previous chapters. Linear deformations are referred to the bottom chord of the truss element, and the angular deformation is defined as the rotation of the line connecting the bottom and top joints of the truss ends. Because of the simplifications associated with the application of redundants at the "elastic center", the elastic center approach is taken in deriving deformation equations for the end moments and thrusts. The redundants are evaluated at the elastic center and then transferred to the ends, thus formulating the desired slope deflection equations. All elastic constants and load functions, and stiffness constants and fixed end reactions are defined and illustrated.

In order to achieve compatibility at the connection of the truss to the column, it was necessary to modify the deformation equations for the column, defining the deformations of the column in the same terms as those for the truss. The application of the moment distribution method of solution and the respective steps to be followed was then outlined and explained.

The theory presented in this thesis is illustrated by a numerical example solved by the slope deflection equations presented in this thesis and by the approximate method of analysis in which the elastic shortening

and the corresponding thrust acting on the bottom chord of the truss are both neglected, while the effective length of the column is taken as the length to the mid-depth of the truss for each column.

6-2. Conclusions

The application of the "exact" slope deflection method presented in this thesis yields the same number of deformation equations for a truss of bent or curved shape as the "approximate" method. For the special case of a straight truss, the exact method yields one additional simultaneous equation for each span (Sec. 5-3). The formulation of the exact deformation equations is not more difficult than the approximate equations, and if computing facilities are available the additional equations for the case of straight trusses is of no consequence.

It is observed in the comparison of results in the numerical example (Table 5-2), that for this special case a significant difference exists between the exact and the approximate results. From this, it is concluded that the approximate method should be applied with caution, and only when the analyst has evidence as to the expected accuracy. Further study is needed to determine the limitations within which the approximate method might give good results. In the meantime it is suggested that the exact method presented in this thesis be used.

6-3. Extension

Having obtained an exact solution by the method of slope deflection or moment distribution for continuous truss frames of one story, the next logical step seems to be to extend the material presented in this thesis to continuous truss frames of more than one story.

The problem would consist primarily of modifying the deformation equations for the columns to obtain compatibility at the truss-column connections at each story.

A SELECTED BIBLIOGRAPHY

1. Gillespie, James W., "Slope Deflection Equations Applied to Trusses," Lecture notes, Civen 5A4 - Theory of Structures III, Oklahoma State University, Stillwater, Summer, 1961.
2. Smith, Lieu R., "Derivation of Slope Deflection Equations for Arched Truss," M. S. Report, Oklahoma State University, Summer, 1957.
3. Morrisett, Dale E., "Derivation of Slope Deflection Equations for Straight Trusses of Constant Depth," M. S. Report, Oklahoma State University, Summer, 1957.
4. Tuma, Jan J., "Analysis of Continuous Trusses by Carry-Over Moments," Journal of Struct. Division, Proceedings A. S. C. E., September, 1958.
5. Gonulsen, Yavuz I., "The Analysis of Rigid Truss-Frames by the String Polygon Method," M. S. Thesis, Oklahoma State University, Summer, 1961.
6. Tuma, Jan J., "Analysis of Truss Frames with Curved and Bent Girders," School of Civil Engineering Research Publication, Oklahoma State University (in preparation).
7. Timoshenko, S. and Young, D. H., Theory of Structures, New York, McGraw-Hill Book Co., Inc., 1945.

VITA

Ezra David Shoua

Candidate for the Degree of
Master of Science

Thesis: ANALYSIS OF CONTINUOUS TRUSS-FRAMES BY SLOPE
DEFLECTION AND MOMENT DISTRIBUTION

Major Field: Civil Engineering

Biographical:

Personal Data: Born on March 20, 1936, the son of David and
Esther Shoua.

Education: Graduated from Comboni College High School and re-
ceived Oxford General School Certificate of Education,
June, 1954; received London University Intermediate
Advanced Level degree, May, 1957; received the Bachelor
of Science Degree (1st Class Honors) in Civil Engineering
from the University of Khartoum, Sudan, March, 1960;
completed requirements for the Master of Science degree
in January, 1962.

Professional Experience: Design Engineer, Khartoum Municipality,
Khartoum; Design Engineer, Emerson, Patterson & Com-
mstock Inc., Pittsburgh, Pennsylvania; Research Assistant,
Carnegie Institute of Technology, Pittsburgh, Pennsylvania;
Teaching Assistant, School of Civil Engineering, Oklahoma
State University.